

Segmented (Mitred) 11 Deg Bend

OD110 – OD630

SDR17 PE100 Black

- Leg lengths long enough for Electro Fusion Welding (not long enough for butt fusion with automatic BF machines)
- Welded from PE100 Black Pipe
- $R = 1.5 \times d$

d (mm)	s (mm)	le (mm)	r (mm)	z (mm)
110	6.6	189	165	194
125	7.4	194	188	200
140	8.3	199	210	206
160	9.5	206	240	214
180	10.7	211	270	222
200	11.9	220	300	230
225	13.4	230	338	241
250	14.8	338	375	350
280	16.6	349	420	362
315	18.7	413	473	428
355	21.1	426	533	443
400	23.7	442	600	461
450	26.7	459	675	481
500	29.7	527	750	551
560	33.2	548	840	575
630	37.4	573	945	603

Note: Dimensions Subject to Change without Notice

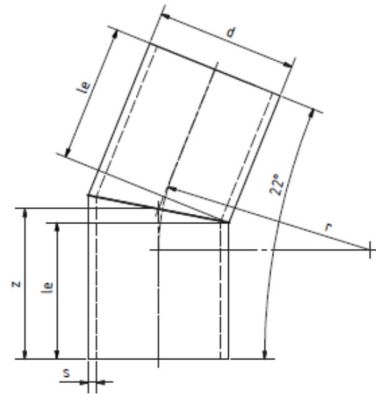

Segmented (Mitred) 22 Deg Bend

OD110 – OD630

SDR17 PE100 Black

- Leg lengths long enough for Electro Fusion Welding (not long enough for butt fusion with automatic BF machines)
- Welded from PE100 Black Pipe
- $R = 1.5 \times d$

d (mm)	s (mm)	le (mm)	r (mm)	z (mm)
110	6.6	183	165	194
125	7.4	188	188	200
140	8.3	192	210	206
160	9.5	198	240	214
180	10.7	203	270	220
200	11.9	211	300	230
225	13.4	219	338	241
250	14.8	326	375	350
280	16.6	335	420	362
315	18.7	397	473	428
355	21.1	408	533	443
400	23.7	422	600	461
450	26.7	437	675	481
500	29.7	502	750	551
560	33.2	521	840	575
630	37.4	542	945	603

Note: Dimensions Subject to Change without Notice

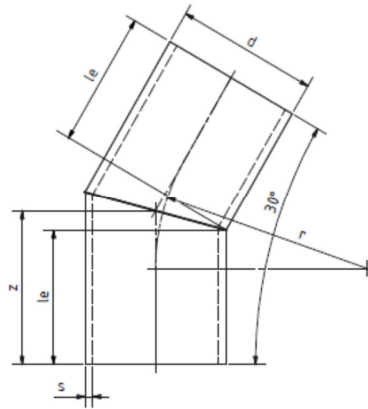

Segmented (Mitred) 30 Deg Bend

OD110 – OD630

SDR17 PE100 Black

- Leg lengths long enough for Electro Fusion Welding (not long enough for butt fusion with automatic BF machines)
- Welded from PE100 Black Pipe
- $R = 1.5 \times d$

d (mm)	s (mm)	le (mm)	r (mm)	z (mm)
110	6.6	179	165	194
125	7.4	183	188	200
140	8.3	187	210	206
160	9.5	193	240	214
180	10.7	196	270	220
200	11.9	203	300	230
225	13.4	211	338	241
250	14.8	317	375	350
280	16.6	327	420	362
315	18.7	389	473	428
355	21.1	395	533	443
400	23.7	407	600	461
450	26.7	421	675	481
500	29.7	484	750	551
560	33.2	500	840	575
630	37.4	519	945	603

Note: Dimensions Subject to Change without Notice

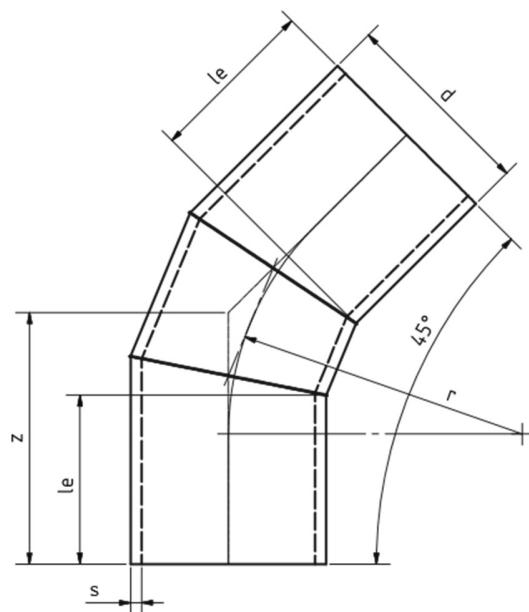

Segmented (Mitred) 45 Deg Bend

OD110 – OD630

SDR17 PE100 Black

- Leg lengths long enough for Electro Fusion Welding (not long enough for butt fusion with automatic BF machines)
- Welded from PE100 Black Pipe
- $R = 1.5 \times d$

d (mm)	s (mm)	le (mm)	r (mm)	z (mm)
110	6.6	172	165	218
125	7.4	175	188	228
140	8.3	178	210	237
160	9.5	181	240	249
180	10.7	186	270	262
200	11.9	190	300	274
225	13.4	195	338	290
250	14.8	306	375	412
280	16.6	306	420	424
315	18.7	365	473	498
355	21.1	370	533	520
400	23.7	379	600	548
450	26.7	390	675	580
500	29.7	454	750	665
560	33.2	461	840	698
630	37.4	475	945	741

Note: Dimensions Subject to Change without Notice

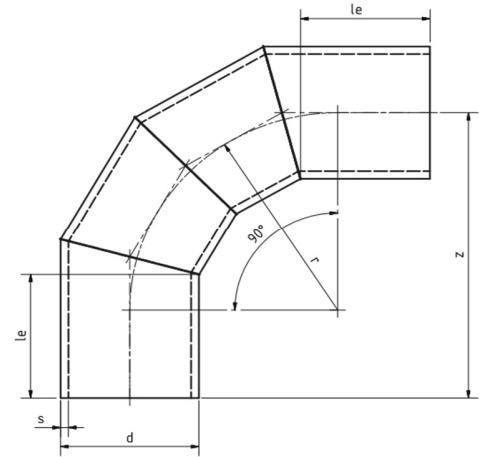

Segmented (Mitred) 90 Deg Bend

OD110 – OD630

SDR17 PE100 Black

- Leg lengths long enough for Electro Fusion Welding (not long enough for butt fusion with automatic BF machines)
- Welded from PE100 Black Pipe
- $R = 1.5 \times d$

d (mm)	s (mm)	le (mm)	r (mm)	z (mm)
110	6.6	179	165	315
125	7.4	184	188	338
140	8.3	188	210	360
160	9.5	193	240	390
180	10.7	189	270	420
200	11.9	204	300	450
225	13.4	211	338	488
250	14.8	317	375	625
280	16.6	325	420	670
315	18.7	390	473	778
355	21.1	396	533	833
400	23.7	407	600	900
450	26.7	421	675	975
500	29.7	484	750	1100
560	33.2	500	840	1190
630	37.4	519	945	1295

Note: Dimensions Subject to Change without Notice