

Segmented (Mitred) 22 Deg Bend

OD110 – OD630

SDR11 PE100 Black

- Leg lengths long enough for Electro Fusion Welding (not long enough for butt fusion with automatic BF machines)
- Welded from PE100 Black Pipe
- $R = 1.5 \times d$

d (mm)	s (mm)	le (mm)	r (mm)	z (mm)
110	10.0	183	165	194
125	11.4	188	188	200
140	12.7	192	210	206
160	14.6	198	240	214
180	16.4	203	270	220
200	18.2	211	300	230
225	20.5	219	338	241
250	22.7	326	375	350
280	25.4	335	420	362
315	28.6	397	473	428
355	32.2	408	533	443
400	36.3	422	600	461
450	40.9	437	675	481
500	45.4	502	750	551
560	50.8	521	840	575
630	57.2	542	945	603

Note: Dimensions Subject to Change without Notice

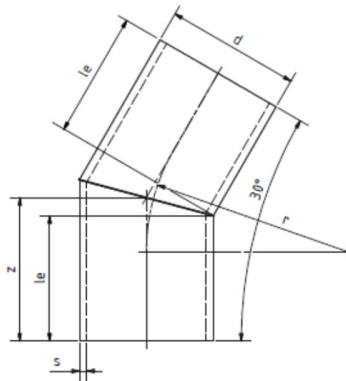

Segmented (Mitred) 30 Deg Bend

OD110 – OD630

SDR11 PE100 Black

- Leg lengths long enough for Electro Fusion Welding (not long enough for butt fusion with automatic BF machines)
- Welded from PE100 Black Pipe
- $R = 1.5 \times d$

d (mm)	s (mm)	le (mm)	r (mm)	z (mm)
110	10.0	179	165	194
125	11.4	183	188	200
140	12.7	187	210	206
160	14.6	193	240	214
180	16.4	196	270	220
200	18.2	203	300	230
225	20.5	211	338	241
250	22.7	317	375	350
280	25.4	324	420	362
315	28.6	386	473	428
355	32.2	395	533	443
400	36.3	407	600	461
450	40.9	421	675	481
500	45.4	484	750	551
560	50.8	500	840	575
630	57.2	519	945	603

Note: Dimensions Subject to Change without Notice

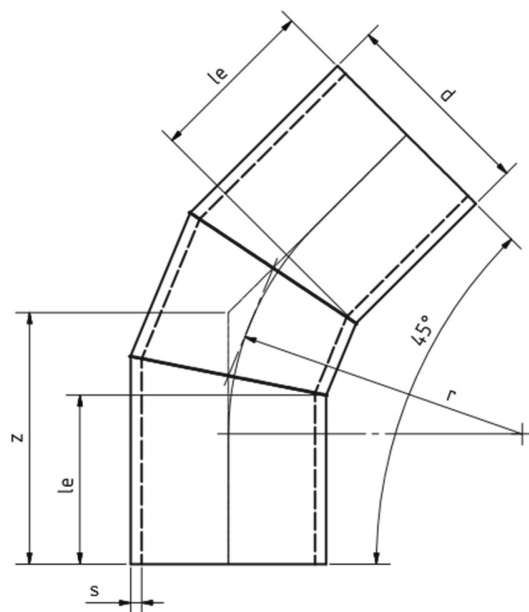

Segmented (Mitred) 45 Deg Bend

OD110 – OD630

SDR11 PE100 Black

- Leg lengths long enough for Electro Fusion Welding (not long enough for butt fusion with automatic BF machines)
- Welded from PE100 Black Pipe
- $R = 1.5 \times d$

d (mm)	s (mm)	le (mm)	r (mm)	z (mm)
110	10.0	172	165	218
125	11.4	175	188	228
140	12.7	178	210	237
160	14.6	181	240	249
180	16.4	186	270	262
200	18.2	190	300	274
225	20.5	195	338	290
250	22.7	306	375	412
280	25.4	306	420	424
315	28.6	365	473	498
355	32.2	370	533	520
400	36.3	379	600	548
450	40.9	390	675	580
500	45.4	454	750	665
560	50.8	461	840	698
630	57.2	475	945	741

Note: Dimensions Subject to Change without Notice

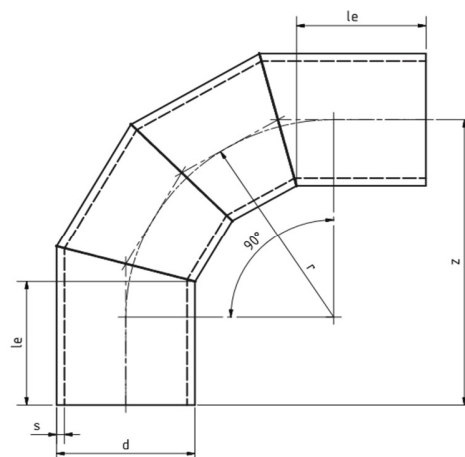

Segmented (Mitred) 90 Deg Bend

OD110 – OD630

SDR11 PE100 Black

- Leg lengths long enough for Electro Fusion Welding (not long enough for butt fusion with automatic BF machines)
- Welded from PE100 Black Pipe
- $R = 1.5 \times d$

d (mm)	s (mm)	le (mm)	r (mm)	z (mm)
110	10.0	179	165	315
125	11.4	184	188	338
140	12.7	188	210	360
160	14.6	193	240	390
180	16.4	189	270	420
200	18.2	204	300	450
225	20.5	211	338	488
250	22.7	317	375	625
280	25.4	325	420	670
315	28.6	390	473	778
355	32.2	396	533	833
400	36.3	407	600	900
450	40.9	421	675	975
500	45.4	484	750	1100
560	50.8	500	840	1190
630	57.2	519	945	1295

Note: Dimensions Subject to Change without Notice